

COMPUTERIZED RELAY TEST SYSTEM CVRT- S8

Automatic Test Equipment (ATE) for Relays
Maximum 8 Contacts. Equipment controlled by
External PC through RS232C Port.

SYSTEM CONNECTIONS

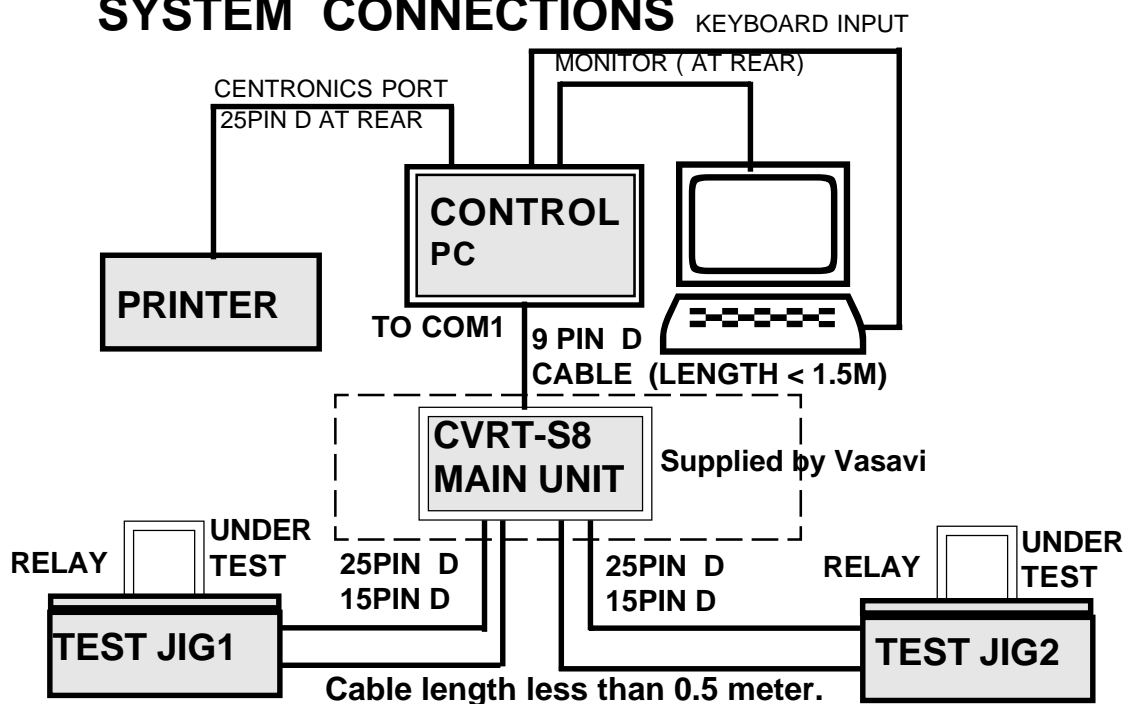

Note: Standard Model CVRT-S8 comes with single Test Jig Port. Can be opted specifically for dual jig version. While the system is testing JIG1 relay we can replace the JIG2 relay. Similarly when it is testing JIG2 relay we can replace JIG1 relay. This will improve the test speed. The handling time can be reduced. The system can be made to test without waiting .

VASAVI ELECTRONICS

95, JYOTHI COLONY, P.O.TRIMULGHERRY
SECUNDERABAD - 500 015. (HYDERABAD) INDIA
web site: <http://www.vasavi.com>
e-mail: info@vasavi.com

BRIEF DESCRIPTION

VASAVI CVRT is designed to make automatic testing of ELECTROMECHANICAL AND READ RELAYS both for static and dynamic characteristics at a single stroke. Testing will be extremely fast and error free. Though people ignore the importance of test data, it is this data which enables improvement in the production process. If testing is manually interpreted there is every possibility of human errors added to the instrument errors. If number of such parameters are more the human error multiplies. VASAVI CVRT is a total solution for above problems for quality conscious people.

The system scans at a stroke all the following parameters:

- | | |
|---|------------------------------------|
| 1. BREAK CONTACT RESISTANCE | 2. COIL RESISTANCE |
| 3. OPERATING CURRENT / VOLTAGE | 4. HOLDING VOLTAGE |
| 5. RELEASING CURRENT / VOLTAGE | 6. CONTACT RES. OF ALL CON. |
| 7. OPERATING TIME | 8. RELEASING TIME |
| 9. BOUNCE TIME | 10. BOUNCE CYCLES |
| 11. TRAVERSE TIME for C/O Relays or with both MAKE & BREAK contacts. | |

The test data can be pre-programmed and stored in the computer disk. The test sequence for all types of relays can be pre-programmed with the help of USER FRIENDLY MENU DRIVEN software. Any semiskilled person can be engaged for actual testing purpose as the operator need not make any settings manually and need not interpret the readings. He need not even know the test procedure and limits. The operator has to simply load test data from the floppy and proceed testing the relays. The system conducts the tests and gives PASS / FAIL indication on overall test results. **If a printer is connected, each test result will be printed. Display of TIMING DIAGRAM / GRAPH ON OPTION.**

Data Base and SQA (STATISTICAL QUALITY ANALYSIS) software ON OPTION.

DATE and TIME OF TESTING

The system maintains time, date and prints at each page of the report if so selected.

CUSTOMER SELECTABLE REPORT PRINTING

Under printer setting menu the user can define the report printing like DATE, TIME, NAME OF COMPANY, NAME OF COMPONENT, BATCH NUMBER, RESULTS etc.

TEST OPTIONS FOR DISPLAY AND PASS/FAIL ANALYSIS

Under TEST DATA menu you can select a number options.

The following selections can be made to be included or not in the report.

DATE, TIME, COMPANY NAME, TEST RESULT, PRINT ONLY IF PASS, PRINT ONLY IF FAIL, OPERATE BOUNCE TIME, RELEASE BOUNCE TIME, OPERATE TRAVERSE TIME, RELEASE BOUNCE TIME, HOLD RESULT, EVERY 10TH TEST, EVERY 50TH TEST, EVERY 100TH TEST, SERIAL NUMBER JUMP BY 10.

SYSTEM CONTROLLED FROM EXTERNAL PC THROUGH RS232C PORT.

RS232C port with baud rate possibility up to 57200 BAUD. (Most of the PC-ATs work.)

OPERATING SYSTEM: Must be DOS 6.0 or higher version. OR Windows98.

TIMING WAVEFORM

This is one of the best features of CVRT. After completing the test the menu displays the tested results in a standard proforma on the screen. You have an option to display the timing diagram of all the contacts by selecting this option. This option is valid only if the corresponding tests ie, OP TIME or RE TIME are selected.

When you select this option the system displays the contact-vice wave form in the form of a graph with reference to the instant of energize or de-energize the relay coil. Basically the system keeps track of each and every selected contact for the duration of operation or Release. It takes samples of their status at standard intervals of time slices. It rebuilds the data in to a waveform. The system has capability to display timing waveform up to 8 contacts.

DEVELOPMENT INFORMATION: This waveform is very useful for the R&D purpose. You can observe the contact behavior for its operation, bounce etc. Please note that the information is of digital nature ie CLOSE or OPEN.

Can expand and view the graphs.

SPECIFICATIONS

1. COIL RESISTANCE (CR): DC RESISTANCE TEST

Range : 40 Ohm - 300 Ohms. $\pm 2\%$ ± 1 dgt.	Resolution: 0.1 Ohm
300 Ohms -1500 Ohms $\pm 1.0\%$ ± 1 dgt	Resolution: 1 Ohm
1500 Ohms - 4000 Ohms $\pm 2.0\%$ ± 1 dgt	Resolution : 10Ohms

2. BREAK CONTACT RESISTANCE (BCR): DC RESISTANCE TEST at 100 mA.

Range : 1 mOhm - 200 mOhms. $\pm 0.5\%$ ± 1 dgt ± 0.2 mOhm. Resol.: 0.1 mOhm

3. MAKE CONTACT RESISTANCE (MCR): DC RESISTANCE TEST at 100mA

Range : 1 mOhm - 200 mOhms. $\pm 0.5\%$ ± 1 dgt ± 0.2 mOhm. Resol.: 0.1 mOhm

4. OPERATING VOLTAGE, RELEASE VOLTAGE , HOLDING VOLTAGE

Setting Accuracy.	Setting Resolution	Measurement Resolution
Up to 24 V $\pm 0.1V$	$\pm 0.1V$	$\pm 0.01V$
24 V to 48V $\pm 0.2V$	$\pm 0.2V$	$\pm 0.05V$

Also display of CURRENT with 0.1 mA Resolution.

5. OPERATING TIME , RELEASE TIME , BOUNCE TIME , TRAVERSE TIME

Range : Up to 50 mSec $\pm 0.5\%$ ± 1 dgt	Resolution : 0.03mSec.
50 mSec to 200 mSec	Resolution: 0.1 mSec.

6. TESTING TIME : Typical 3-5 Sec per fast relay by using proper test jig

Test time will be more for slow relays.

7. NUMBER OF CONTACTS : 8 maximum either make or break together.

8. COIL VOLTAGE : 5V, 6V, 9V 12V, 18V, 21V, 24V, 36V, 48V selected by the menu.

9. MONITORING CONTACTS : 8 contacts

TEST JIG

The system is provided with Test Jig ports for handling the components. The user has to make suitable test jigs for each type of component and terminate the connections to these ports. The main main instrument has two pairs of male D type connectors on its front panel 9 PIN D MALE for coil and 25 PIN D MALE for contacts. The Contact resistance is highly dependent on the type of connections made as the terminal or wiring resistance will be considerable compared to contact resistance being measured. To avoid this problem KELVIN type of contacts must be used for each pair of contacts for which contact resistance is being measured.

For each set there must be

CONTACT DRIVE HI - CD, CONTACT SENSE HI - CSH

CONTACT DRIVE LO - CDL, CONTACT SENSE LO - CSL

As shown in MENU

As shown in Diagram (Con Pin Nos.)

CONT 1.	CD1(13)	CSH1(25)	CDLO(1)	CSL1(5)
CONT 2.	CD2(12)	CSH2(24)	CDLO(1)	CSL2(17)
CONT 3.	CD3(11)	CSH3(23)	CDLO(1)	CSL3(4)
CONT 4.	CD4(10)	CSH4(22)	CDLO(1)	CSL4(16)
CONT 5.	CD5 (9)	CSH5(21)	CDLO(1)	CSL5(3)
CONT 6.	CD6(8)	CSH6(20)	CDLO(1)	CSL6(15)
CONT 7.	CD7(7)	CSH7(19)	CDLO(1)	CSL7(2)
CONT 8.	CD8(6)	CSH8(18)	CDLO(1)	CSL8(14)

Relay coil must be connected to 9 pin D connector PIN NOS.6/7 & 8/9.

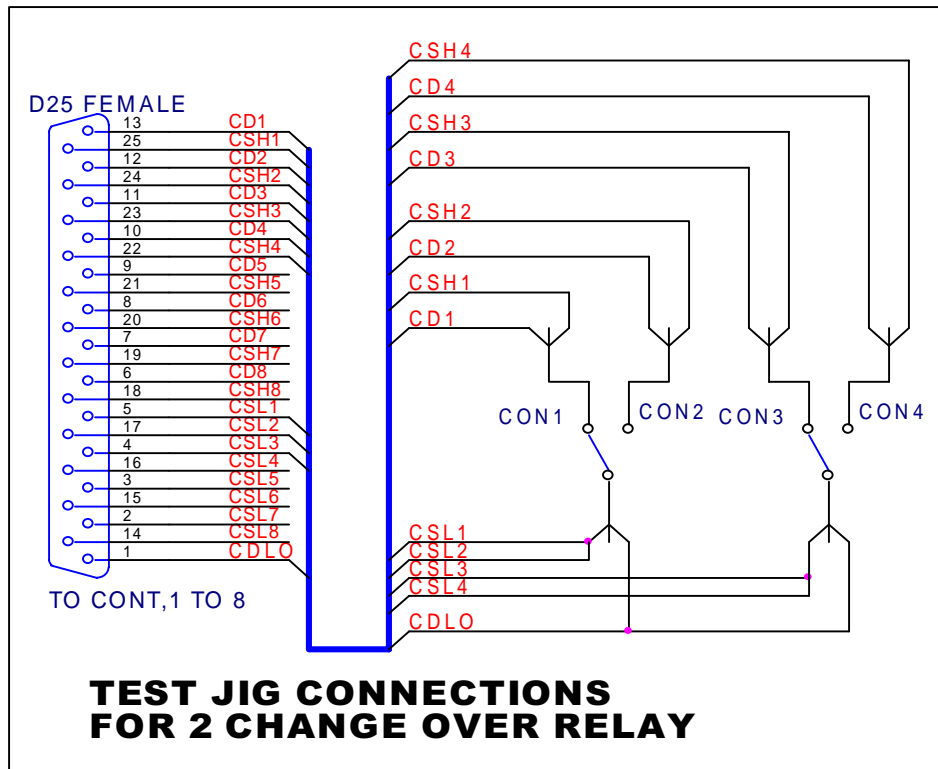

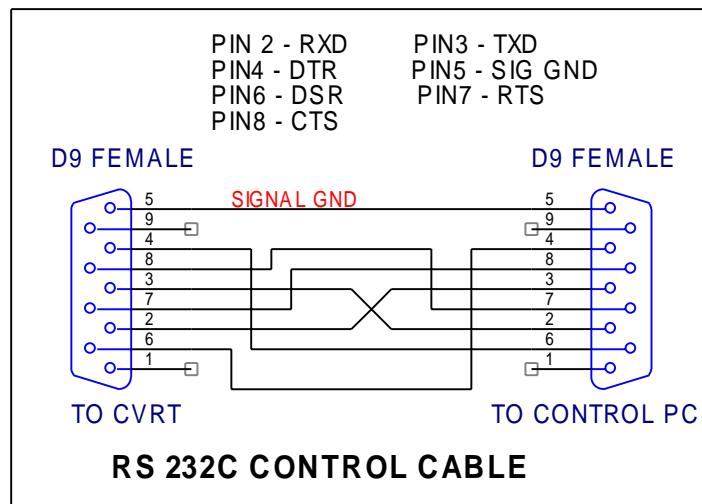
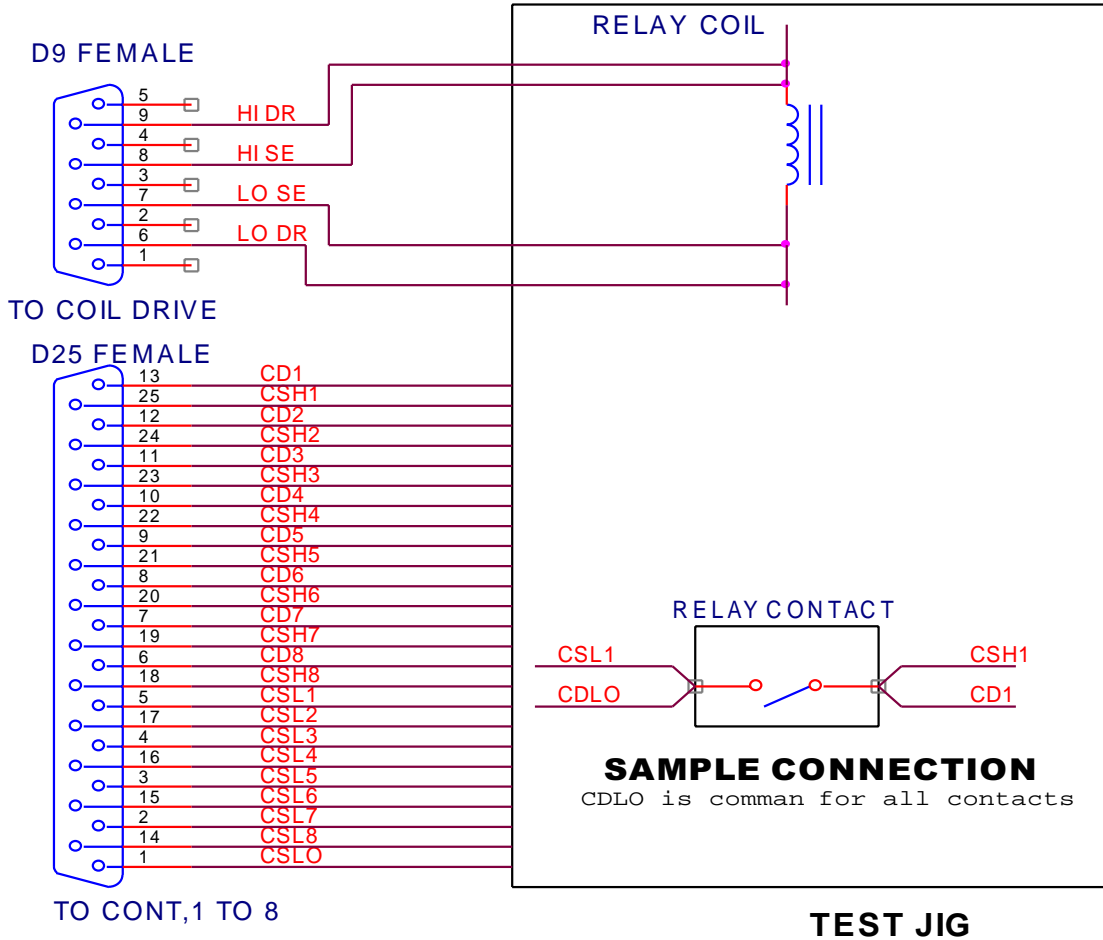

RS232C COMMUNICATION

The system consists of three main parts. 1. CONTROL PC (not supplied) 2. RELAY TEST SYSTEM CVRT-S8 (MAIN UNIT) 3. TEST JIG. (not supplied)

The control software is run in the control PC. The software provides all the menus, displays the results and prints the report if wanted. The actual measurements are done in the main unit. This unit works under the control of PC. The control is implemented through RS232C serial communication. PC uses its RS232C port for the control. All the PCs will have this port as a standard facility. In some PCs there will be more than one such ports named as COM1 and COM2.

OPERATION

The system works on DOS 6.0 or higher versions or WINDOWS 98. CVRT must be connected to COM1. If you would like to control CVRT with COM2 port you can do so, but each time you start the control program you have to set the System Configuration under Options Menu selection.

START THE TEST SYSTEM:

Run the control program (program name CVRT or RT32S8) and press ENTER. Take care that the control cable is connected to the appropriate port.

SELECT A TEST DATA:

Assume that you have a test procedure already in the disk and you would like to test the RELAY. Press the function key **F3**. You will see "SELECT COMPONENT" menu where in the available test files are displayed. Press **ENTER**. Cursor will go into files list. Use UP/DOWN keys and locate the interested test file and press **ENTER**. The test file is loaded into the system and you are ready to start testing of the components. If your file is not present in the current directory you can go the required directory by selecting the directories and go to the required directory and load the file.

TEST THE RELAYS:

After loading the test file connect the corresponding jig to the system. Now ready for testing. The operator has nothing to do with the parameters and other details. He has to simply insert the relay into the jig and press start key. Assume that you have the jig and connected the jig. Now press function key **F9**. If you insert the relay and if the relay has NC contacts then the system automatically senses the relay and proceeds for testing the moment relay is placed. After completing the defined tests the results are displayed in the monitor. If printer is connected and if printer setting menu is set for print then the tested values are printed in a tabular form.

To start testing or repeat testing you can **press SPACE BAR** of the key board. The test is in progress and the individual tested parameters are displayed on the monitor display. After completing the testing **press ESCAPE** key to come out of testing. You will see message indicating that system is released from testing. To proceed from the message **press ENTER** key. Now you are back in the main menu.

DATA BASE GENERATION SOFTWARE

The test results can be transferred to the data base file with file extension of *. **DBF** after each test of the component. The database structure is automatically taken from the test data file while creating test file. The data saved in the data base file can be analyzed under database programs like FoxPro or can be imported to Excel for any suitable analysis.

TEST DATA OPTIONS :

Create test data panel has a number of OPTION check boxes.

[x] Display BOUNCE and [x] Display TR.TIME

Though the bounce and traverse times are tested they are not displayed as default. In many specifications these are not specified as test parameters. However if you need the display of Bounce or Traverse times you can select these option individually.

[x] RE. INCLUDE DE-ENERG.

Operate time is solely defined by the relay coil characteristics. So there is no ambiguity about Operate time. However the Release time is a function of both relay coil and also the drive for the coil. (in this system a diode provided for return path across the coil for discharge.) So some of the manufacturers define release time time excluding de-energize time of the coil. So based on your definition select this option. When you check this option the release time also includes de-energize time.

[x] GONOGO ON OP.BOUNCE and [x] GONOGO ON RE.BOUNCE

Some relay manufacturers specify Operate and Release bounce times and some may not. So for the convenience of the user we have provided these options. If you wish that the relay must be passed only when it meets the OP or RE Bounce times you can select these options individually. You can select only OP bounce or RE bounce or Both. In case you do not want to effect the Pass Fail of the relay but wish to observe the Bounce times you can select only display bounce options separately.

[x] GONOGO ON MUST NOT OP.

If your specification of relay also includes Pass Fail of the relay based on must bot operate voltage, you can select this option. When you select this option the system will check whether the relay operated below this set voltage. If so it shows relay as Fail.

[x] GONOGO ON HOLD VOLT.

When you select this option the system apply nominal voltage wait for operation and then reduces voltage to hold voltage suddenly. Then it checks whether any bounce or break in the contacts. If so the relay test is shown as FAIL.

[x] AUTO START .

Normally the test is started by pressing a key of the key board of control system. In single jig version any key except ' T ' will start the test. Do not use function keys. In Dual Jig version Jig 1 starts testing when you press space bar and Jig2 starts testing when other keys except ' T ' is pressed. While the system is in TEST IN PROGRESS mode, the keys are ignored if any. To avoid this key board operation AUTO START TEST ON option is provided. You can avail this option only when at least one contact has NORMALLY CLOSED contact in the relay. When this option is selected the system looks for the placement of relay in the jig. It will be monitoring all the specified NC contacts. When it finds the contacts are closed; it starts testing. After completing the testing and display , it will wait for removal of the relay by monitoring the NC contacts. After these contacts are found to be open it will look once again for closing of NC contacts. If another relay is placed in the jig the system starts testing again. Thus testing becomes automatic.

Apart from this the system also provides a set of LED drives in the COIL Connector for displaying TESTING, PASS, FAIL, INSERT . By using these LED indicators and AUTO START TEST ON option; the operator need not look at the monitor display for results. Operator can concentrate on the jig itself. By doing so the operators strain is reduced and speed of Operation will be increased by a large extent.

MECHANIZATION OF TESTING:

By using above mode and with appropriate mechanical handler you can make testing fully automatic without involving any person for handling the relays.

Vasavi can provide control signals to synchronize the machine. (at extra cost). For such requirements contact Vasavi. (Note that Vasavi will not provide or develop any handling machine). The users must arrange a handling machine and jigs themselves.

[x] TEST COIL RES.

If you want to test Coil Resistance measurement select this option .

[x] TEST CONTACT RES.

If you want to test contact resistance measurement select this option.

[x] TEST OP/RE VOLTS

If you want operating, releasing voltage tests select this option.

[x] OP/RE VOLTS STEP MODE

In stead of testing OPRE voltage in ramp mode you can use this option to test OP/Re with step operation with MUSTNOT OPERATE, MUST OPERATE, MUST NOT RELEASE, MUST RELEASE voltage steps and verify at the limiting voltages. This would save some test time.

[x] REL TEST START VOLTS

In some cases you may need to test the release voltage starting from some other voltage than the nominal voltage. In such case you can select this option and enter the start voltage in the corresponding limits.

[x] TEST OP/REL TIMES.

By selecting this option all the time tests, namely OPERATE TIME, RELEASE TIME, will be tested.

[x] DISPLAY BOUNCE

If you want to display the Bounce times select this option.

[x] DISPLAY OP/RE CUR.

The system basically tests the voltages for operation and release. The limits are also given for coil voltages. However if you would like to see the currents to be displayed along with voltages, you can select this option. Please note that this is meant only for display. Limits are not checked with respect to currents.

[x] RE.INCLUDE DEENERG

The release time can be tested including or excluding deenergization time.

[x] OPT/RET EXCLUDE BOUNCE

The Operate and release times can be tested including or excluding bounce times.

[x] PASS/FAIL OP.BOUNCE

The pass or fail of the relay can be also taken into account by Operate bounce time. You can even display bounce time without effecting the pass fail criteria by not selecting this.

[x] PASS/FAIL OP.BOUNCE

[x] PASS/FAIL RE.BOUNCE (mS)

The pass or fail of the relay can be also taken into account by Operate/Release bounce time. You can even display bounce times without effecting the pass fail criteria by not selecting this.

DEFINITIONS OF TEST PARAMETERS

OPERATING TIME / PICK-UP TIME : The time that is taken by the relay from application of rated voltage to change the state of all the contacts. This time includes traverse time and bounce times.

RELEASING TIME / DROP AWAY TIME : The time that is taken by the relay from removal of rated voltage to change the state of all the contacts. Normally this time includes coil de-energize time, traverse time and bounce times. However you have an option to ignore de-energize time.

OPERATE TRANSFER TIME (For relay with NC NO contacts only) : Time interval between breaking of first back contact (or NC contact) and making of first front contact (or NO contact).

RELEASE TRANSFER TIME (For relay with NC NO contacts only): Time interval between breaking of first front contact and making of first back contact.

OPERATE BOUNCE TIME FOR NO. (FRONT CONTACT) : Maximum of the rebound duration of each individual contact during operate time.

CONTACT BOUNCE TIME FOR NC (BACK CONTACT) :Maximum of the rebound duration of each individual contact during release time.